

# The use of Polarisation Interleaving to Reduce Crosstalk in a Fibre Optic mm-Radio WDM system.

William J. O'Brien, J. J. O'Reilly, University College London.

**Abstract.***In this paper the origins of crosstalk in DWDM millimetre hybrid fibre radio networks are discussed. A means by which polarisation interleaving might be implemented with a view to reducing the impact of crosstalk is explained analytically. It is concluded that with standard fibre and continuous wave transmission polarisation interleaving provides little benefit if used over distances greater than a few km, due to depolarisation.*

## 1. Introduction

As our demand for high data rates increases we need to find flexible ways for delivering the necessary bandwidth. One solution is the hybrid fibre radio (HFR) network. It uses fibre optics to carry data for the bulk of the network, possibly a passive optical network in a star-tree architecture, with a wireless connection providing the last drop. This could be used to provide a wireless local loop or Wireless Local Area Networks (WLANs). HFR could provide a successor to UMTS in mobile communications and intelligent vehicle highway systems (IVHS) represent another prospective application [1].

The limited spectrum available at low GHz frequencies currently used for GSM highly restricts the channel bandwidth that can be allocated. The availability of bandwidth at higher, millimetre frequencies is greater. Various bands between 30 and 60GHz have been cited. A large concentration of base stations (BSs) would be required to allow for the high atmospheric attenuation, indeed cell diameters of picocellular size (<100m) are likely.

Various ways of delivering a millimetre-wave signal via fibre optics have been researched. It is a common approach to generate a two tone, or self-heterodyne, spectrum by modulating a DFB laser at 1550nm with a Mach-Zehnder modulator (MZM) biased at  $V_\pi$  (the voltage that produces a  $\pi$  phase difference between the two arms). The data can be modulated onto either or both of the tones. The difference in frequency between the two tones is the required millimetre-wave frequency (called  $f_{mm}$  from this point on) [2]. A signal at  $f_{mm}$  can be filtered out from the output of a P-I-N photodiode at the base station. The main reason for generating this kind of spectrum is that although dispersion in standard fibres is non-zero at 1550nm this does not lead to the length-dependent fading that would occur with a three tone spectrum [3], provided that the carrier is sufficiently well suppressed.

In order to utilise the bandwidth of an optical fibre most efficiently we can use dense wavelength division multiplexing (DWDM) with channels separated by as little as 100GHz (0.8nm). The drawback of such close channel packing is crosstalk. Non-linear effects associated with MZMs lead to the existence of unwanted sidebands at frequencies that are multiples of  $f_{mm}$  away from the optical carrier, effectively broadening the spectrum of each channel. These sidebands might be partially accepted into adjacent channels on demultiplexing. An arrayed waveguide demultiplexer would be appropriate to handle such closely packed channels. The shape of its transmission function with frequency for any one channel is Gaussian [4]; whereas ideally each channel filter would have sharp edges.

One means of cutting down the level of crosstalk is to employ polarisation interleaving. This is a scheme where adjacent channels are launched into the fibre at orthogonal polarisations. Such signals could be separated prior to mixing using a

polarisation beamsplitter. Figure 1 shows a possible set up for polarisation interleaved DWDM mm-radio system. In this set up, data is modulated onto each channel by direct modulation of drive current, the IF sub-carrier method. There is a problem with single mode fibres, which is they are not truly single mode. The small anisotropy in the glass in the fibre's core leads to birefringence and a break in the degeneracy the two modes. Power can couple between the two modes, limiting the potential of polarisation interleaving.

Calculations have been made to evaluate how much crosstalk power can leak from one channel to another for varying amounts of depolarisation. This has been compared to the situation where no polarisation interleaving is employed.

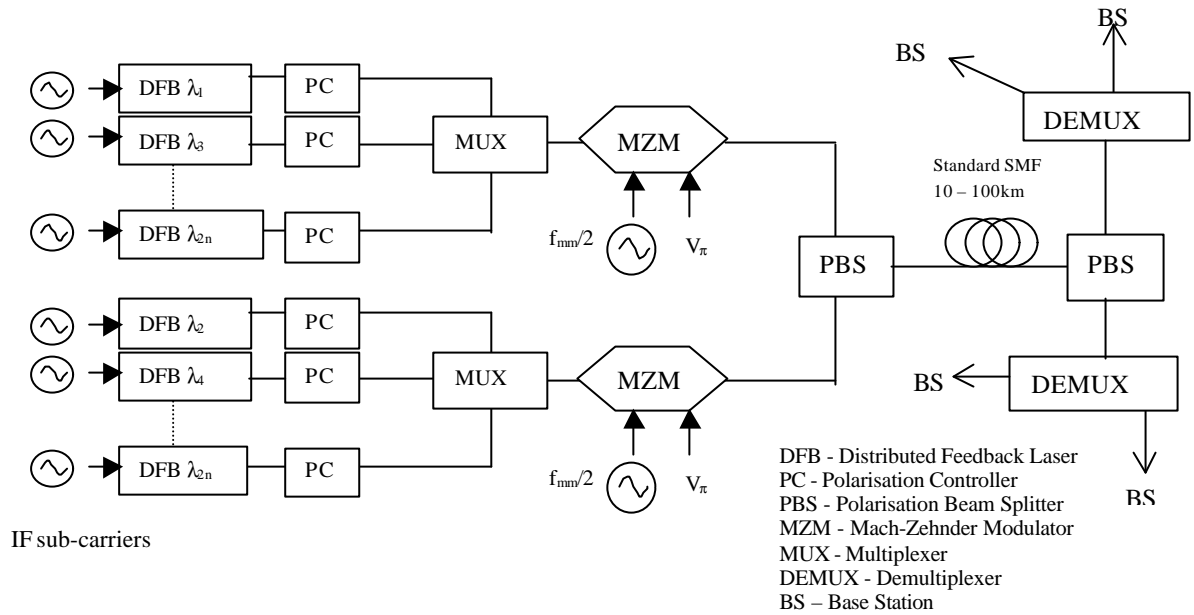

Figure 1. Possible set up for employing a polarisation interleaving DWDM system to deliver a mm-radio signal to base stations.

## 2. The mm-radio WDM spectrum

If the drive voltage applied to the lower arm of the MZM is given by

$$v(t) = V_{\pi}(1 + \varepsilon + \alpha \cos(\pi f_{mm} t)) \quad (1),$$

where  $\alpha$  is the normalised drive voltage amplitude and  $\varepsilon$  is the normalised bias voltage. The output field from the modulator can be represented as a series of Bessel functions as follows:

$$E(t) = \frac{1}{2} J_0 \left( \alpha \frac{\pi}{2} \right) \cos \left( \frac{\pi}{2} (1 + \varepsilon) \right) \cos(2\pi f_{DFB} t) + \sum_{n=1}^{\infty} J_n \left( \frac{\alpha \pi}{2} \right) \cos \left( \frac{\pi}{2} (n + 1 + \varepsilon) \right) \left( \cos(2\pi (f_{DFB} + \frac{nf_{mm}}{2}) t) + \cos(2\pi (f_{DFB} - \frac{nf_{mm}}{2}) t) \right) \quad (2)$$

where  $f_{DFB}$  is the DFB laser frequency. In the frequency domain we have an infinite set of sidebands separated by  $f_{mm}$ . If we biasing close to the bias point, such that  $\varepsilon \ll 1$ , the first term, and all of the even-numbered terms are suppressed. The  $n = 1$  terms are the strongest, and it is these two that beat to produce the signal we want.

In calculation all spectral components are assumed to be delta functions in frequency. All terms beyond  $n=5$  have been considered negligible.

### 3. Calculation of Crosstalk

When two sinusoidal electromagnetic waves are added together the intensity detected by a PIN diode is proportional to the square of the modulus of the electric field vector. A term at the difference frequency between the two components is produced. This means that when any pair of components in the channel spectrum that are separated by  $f_{mm}$  are mixed together, a pure sinusoidal electrical signal at  $f_{mm}$  is produced. All other mixing terms can be ignored because they can be easily filtered out. However component pairs in adjacent channels that are separated by  $f_{mm}$  also produce a signal at  $f_{mm}$ . The data modulated onto it is unlikely to be the same, so this causes crosstalk and an increased bit error rate.

### 4. Polarisation Decorrelation

Although the magnitude of the birefringence in modern fibres is small,  $B \sim 10^{-7}$ , it changes in direction and such causes the orientation of the polarisation eigenmodes to rotate, and does so over a characteristic length scale of  $\sim 100\text{m}$  [5]. There is also a periodic beating of power between the modes over a characteristic length of about  $10\text{m}$  ( $=\lambda/B$ ). The third effect is called mode coupling where small fluctuations in the birefringence due to bends, lateral strain or residual ellipticity can cause power to be irreversibly transferred between the polarisation eigenmodes. The amount of energy that is transferred from one mode to another in these circumstances is proportional to the amount of energy in that mode, such that plane polarised light degrades exponentially with distance to ultimately become unpolarised. Beyond such a distance, the benefits of utilising polarisation interleaving are limited.

There are potential benefits in using polarisation-preserving fibre. These are intentionally fabricated such that their birefringence is high ( $\sim 10^{-4}$ ) and of defined orientation. With these fibres the state of polarisation of plane polarised is retained much better. The slow and fast axes are unable to rotate and no beating takes place, provided that the polarised light is aligned with either the slow or the fast axis of the fibre. Polarisation mode coupling still takes place, but it is less significant, their mode coupling rate might be as low as  $10^{-7}\text{m}^{-1}$  as opposed to  $0.001\text{m}^{-1}$  for standard fibre [5], [6].

If mode coupling is the only effect taking place the degree of polarisation (DOP) decays exponentially with distance

$$\text{DOP}(z) = \text{DOP}(0) e^{-z/d} \quad \text{where} \quad \text{DOP}(z) = \frac{I_{\max}(z) - I_{\min}(z)}{I_{\max}(z) + I_{\min}(z)} \quad (3).$$

The distance over which the degree of polarisation is reduced to  $1/e$  of its initial value is called the decorrelation length,  $d$  [5]. This is equal to the reciprocal of twice the coupling rate [6].

### 5. Reduction in Crosstalk due to Polarisation Interleaving

Figure 2 shows how the signal to crosstalk ratio changes with frequency and with fibre length with  $\text{DOP}(0) = 1$ . Three channels were defined and the crosstalk leaking into the central one from the other two was calculated, with the channel spacing set at  $100\text{GHz}$ . The transmission function at the demultiplexer was assumed to be Gaussian with an FWHM of  $40\text{GHz}$ . The bias voltage deviation from  $V_\pi$  was set at  $0.01V_\pi$  and the drive amplitude was set at  $0.1V_\pi$ . The impact of crosstalk at higher frequencies is likely to be more severe. In addition, signal loss is higher at higher frequencies, aggravating the problem.

To assess the potential of polarisation interleaving, it has been compared to the situation where the degree of polarisation is 0 at all distances but by keeping the total

power in both modes kept the same. With the assumptions previously stated, the fractional decrease in crosstalk is independent of the channel spacing and the width of the channel filter. Figure 3 shows that beyond 4 decorrelation lengths the improvement is negligible. The level of improvement at distances below 0.1 decorrelation lengths is more significant.

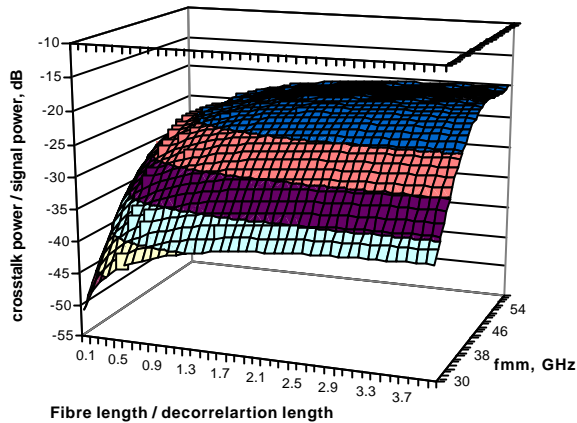

Figure 2. Crosstalk power as a function of fibre length and mm-frequency.

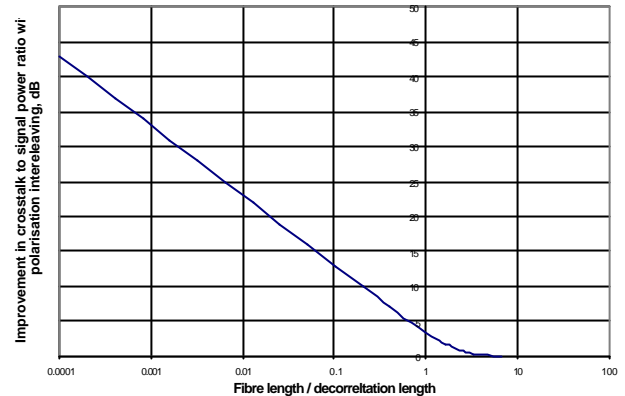

Figure 3. Improvement in crosstalk in dB when comparing a polarisation interleaved DWDM mm-radio system with an ordinary DWDM system.

## 6. Conclusion

A simple model has been developed to demonstrate the potential of utilising polarisation interleaving in a DWDM mm-radio system. It appears that the benefit of using polarisation interleaving is limited due to polarisation decorrelation. The possibility of using polarisation-preserving fibres seems promising with decorrelation lengths ranging from 100 - 10000km, compared to a few km for standard fibre, seems promising. However polarisation preserving fibres are not generally suited for long distance communications, mainly due to their higher losses.

The problems of using standard fibre could be partly alleviated if the network architecture and frequency planning allows us to separate adjacent channels from each other in the core of the network. The extent to which this is possible will depend on cell sizes and the number of channels involved, a subject for further study.

## 7. References

- [1] Remote Delivery of Video Services using mm-Waves and optics. J. J. O'Reilly and P. M. Lane, IEEE Journal of Lightwave Technology, Vol. 12, No. 2, Feb 1994, pp 369-375.
- [2] Optical Generation of Very Narrow linewidth mm-wave signals, J.J. O'Reilly, P.M. Lane, R. Heidemann and R. Hofstetter, IEE Electronics Letters Vol. 30, 1992, pp 2309-2311.
- [3] Comparison of Optical Millimeter-wave system concepts with regard to chromatic dispersion, H. Schmuck. IEE Electronics letters, September 1997.
- [4] Radio over Fibre Distribution Using an Optical Millimetre-Wave/DWDM Overlay, Griffin, Lane and O'Reilly. 1999 Optical Fibre Communications Conference, pp 70-72.
- [5] Polarisation Mode Dispersion, Decorrelation and Diffusion in optical Fibers with Randomly Varying birefringence, P. K. A. Wai and C. R. Menyuk, IEEE Journal of Lightwave Technology, Vol. 14, No. 2, July 1996, pp 148-157.
- [6] Evaluation of Polarisation Mode Coupling Coefficient from Measurement of Polarisation Mode Dispersion, Makoto Tsubokawa, Nori Shibata and Shigeyuki Seikai, IEEE Journal of Lightwave Technology, Vol. LT-3, No. 4, August 1985, pp 850-853.